

Dimensioni d'ingombro

Overall dimensions

Cilindro con deceleratori pneumatici $\varnothing 32 \div 200$ - Cylinders with adjustable cushioning $\varnothing 32 \div 200$

CHIAVE CODIFICA

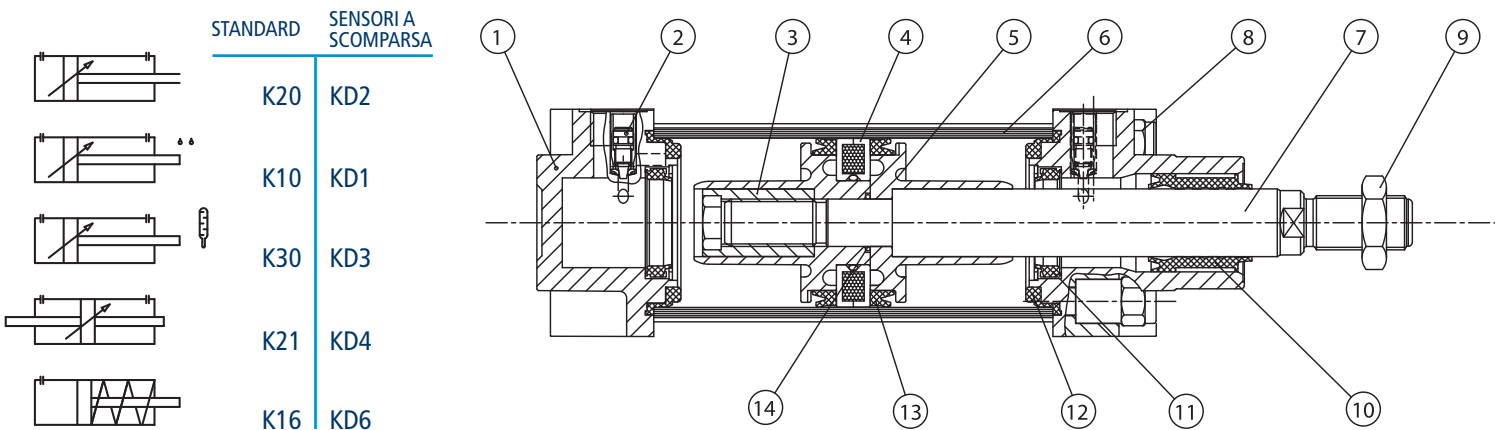

Dimensioni d'ingombro

Overall dimensions

Fluido: aria filtrata, lubrificata e non.

Media: filtered air, lubricated and otherwise.

Pressione di esercizio: Max 10 bar

Working pressure: Max 10 bar

Velocità max: 1 m/s

Max speed: 1 m/s

Temperatura ambiente: -20° C a +80° C

Ambient temperature: -20° C a +80° C

ATTENZIONE:

PRELUBRIFICATI CON GRASSO SPECIALE.

NORMALMENTE NON È RICHIESTA UN'ULTERIORE LUBRIFICAZIONE.

EVENTUALE LUBRIFICAZIONE DURANTE IL FUNZIONAMENTO, DOVRÀ ESSERE CONTINUATIVA.

ATTENTION:

PRELUBRICATED BY SPECIAL GREASE,

FURTHER LUBRICATION IS NOT NORMALLY NECESSARY.

IF ADDITIONAL LUBRICATION IS INTRODUCED, IT MUST BE CONTINUED.

ALESAGGI / CORSE

Semp. eff. d. 32 ÷ 63 0 ÷ 150 mm.

Doppio eff. d. 32 ÷ 80 0 ÷ 2800 mm.

d. 100 ÷ 200 0 ÷ 2600 mm.

BORES / STROKES

Single-acting d. 32 ÷ 63 0 ÷ 150 mm.

Double-acting d. 32 ÷ 80 0 ÷ 2800 mm.

d. 100 ÷ 200 0 ÷ 2600 mm.

Parti meccaniche - *Mechanic items*

POS.	DESCRIZIONE	MATERIALE	TRATTAMENTO SUPERF.
1	TESTATA ANT. POSTER.	Lega GD-ALSi12Cu	Verniciatura a polveri
2	VITE REGOLAZIONE AMM.	OT 58	
3	BUSSOLA SERRAGGIO PISTONE	Acciaio 9SMnPb23	Zincatura
4	GUIDA PISTONE	Resina acetlica POM	
5	PISTONE	Lega GD-ALSi12Cu	
6	CAMICIA	Lega alluminio 6063T6 Ra 0.4	Anodizzazione 20 micron
7	STELO	Acciaio C40 cromato/INOX AISI 303 rullato	
8	VITI FISSAGGIO	Acciaio 9SMnPb23	Zincatura
9	DADO	Acciaio	Zincatura

Elementi di tenuta - *Seal items*

POS.	DESCRIZIONE	MATERIALE	CARATTERISTICHE TEC.	COSTRUTTORE
10	BOCCOLA GUIDA/TENUTA STELO	Poliuretano PU 85ShA	Max 16 bar/ -35+80° C Max 1 m/s	PARKER-PRADIFA
11	GUARNIZIONE PER AMMORTIZZO	Poliuretano PU 90ShA	Max 16 bar/ -30+80° C Max 1 m/s	BUSAK-SHAMBAN
12	PARACOLPO MECC. TENUTA CAMICIA	Gomma nitrile NBR	-35÷100° C	MEC FLUID 2
13	GUARNIZIONE TENUTA PISTONE	Poliuretano PU 90ShA	Max 16 bar/ -30+80° C Max 1 m/s	BUSAK-SHAMBAN
14	GUARNIZIONI TENUTA STATICA "OR"	Gomma nitrile NBR	-35÷100° C	

Dimensioni d'ingombro

Overall dimensions

Cilindro con deceleratori pneumatici Ø 32 ÷ 200 - Cylinders with pneumatic cushioning Ø 32 ÷ 200

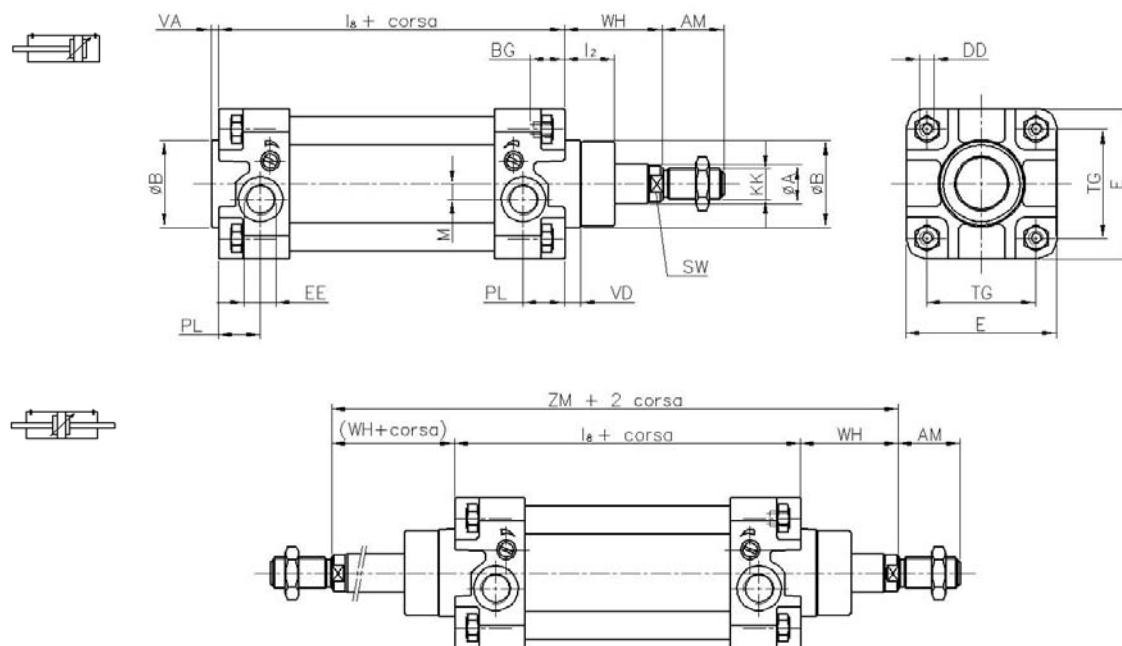

Cil. Ø	A	AM*	B _{e11}	BG	DD	E	EE	l ₂	l ₈ Nom.	Toll.	KK*	M	PL	SW	TG Nom.	Toll.	VD	VA	WH	ZM
32	12	22	30	14	M6	48	G 1/8	16	94	±0,4	M10x1,25	4,5	15	10	32,5	±0,5	5	3	26	146
40	16	24	35	14	M6	54	G 1/4	20	105	±0,7	M12x1,25	5	18	13	38	±0,5	6	4	30	165
50	20	32	40	16	M8	67	G 1/4	26	106	±0,7	M16x1,5	6	18	17	46,5	±0,6	6	4	37	180
63	20	32	45	16	M8	78	G 3/8	26	121	±0,8	M16x1,5	8	21,5	17	56,5	±0,7	6	4	37	195
80	25	40	45	16	M10	97	G 3/8	32	128	±0,8	M20x1,5	7,5	21,5	22	72	±0,7	8	4	46	220
100	25	40	55	16	M10	115	G 1/2	35	138	±1	M20x1,5	9	21,5	22	89	±0,7	8	4	51	240
125	32	54	60	20	M12	140	G 1/2	45	160	±1	M27x2	11	24,5	27	110	±1,1	10	6	65	290
160**	40	72	65	25	M16	180	G 3/4	50	180	±1,1	M36x2	14	29	36	140	±1,1	10	6	80	340
200**	40	72	75	25	M16	220	G 3/4	60	180	±1,1	M36x2	14	29	36	175	±1,1	12	6	95	370

Cil. Ø	Sez. utile (mm ²)	Pressione d'esercizio (bar)					L. deceleratori (mm)	Energia cinetica ass. (Nm)
		2	4	6	8	10		
32	spinta	804	161	322	482	643	18	1,8
	trazione	691	138	276	414	553		
40	spinta	1256	251	502	754	1005	24	2,5
	trazione	1056	211	422	633	844		
50	spinta	1962	393	785	1178	1570	24	4,5
	trazione	1649	330	660	990	1320		
63	spinta	3116	623	1246	1869	2493	30	8
	trazione	2802	560	1120	1680	2240		
80	spinta	5024	1005	2010	3014	4019	30	12
	trazione	4533	907	1814	2722	3629		
100	spinta	7850	1570	3140	4710	6280	35	21
	trazione	7359	1472	2944	4416	5888		
125	spinta	12266	2453	4906	7359	9812	35	36
	trazione	11462	2294	4588	6882	9176		
160	spinta	20096	4019	8038	12058	16077	45	52
	trazione	18400	3770	7540	11310	15080		
200	spinta	31400	6280	12560	18840	25120	45	95
	trazione	30144	6029	12058	18086	24115		

* Le dimensioni "KK" e "AM" corrispondono al tipo ISO 4395 "lungo".
"KK" and "AM" dimensions correspond to the ISO 4395 "long" type.

** Cil. Ø 160 e Ø 200 esecuzione con camicia tubolare in alluminio e tiranti in acciaio - Ø 160 and 200 cylinders, execution with aluminium tube and steel tension rods.

Tolleranze nominali sulla corsa Stroke tolerance

Cil. Ø	Corse (mm)	Tolleranze sulla corsa (mm)
32	fino a 500	+ 2 0
	da 501 a 1.250	+ 3,2 0
40	fino a 500	+ 2,5 0
	da 501 a 1.250	+ 4 0
50	fino a 500	+ 4 0
	da 501 a 1.250	+ 5 0
63	fino a 500	+ 4 0
	da 501 a 1.250	+ 5 0
80	fino a 500	+ 4 0
	da 501 a 1.250	+ 5 0
100	fino a 500	+ 4 0
	da 501 a 1.250	+ 5 0
125	fino a 500	+ 4 0
	da 501 a 1.250	+ 5 0
160	fino a 500	+ 4 0
	da 501 a 1.250	+ 5 0
200	fino a 500	+ 4 0
	da 501 a 1.250	+ 5 0

Flangia anteriore-posteriore in acciaio zincato, ISO MF1-MF2 completa di n. 4 viti di fissaggio
Front/rear flange in zinc-plated steel, ISO MF1-MF2 with 4 fixing screws

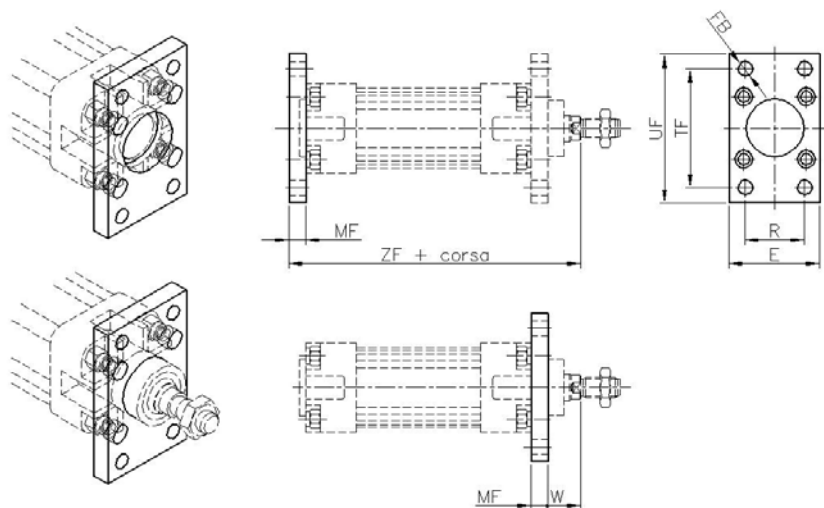

Cil. Ø	Codice	Massa Kg.
32	FM-I12032	0.2
40	FM-I12040	0.25
50	FM-I12050	0.5
63	FM-I12063	0.65
80	FM-I12080	1.5
100	FM-I12100	2.2
125	FM-I12125	4.1
160	FM-I12160	7
200	FM-I12200	12.4

Piedino ad angolo in acciaio zincato ISO MS1, completo di n° 2 viti di fissaggio
Angle bracket in zinc-plated steel ISO MS1, with 2 fixing screws

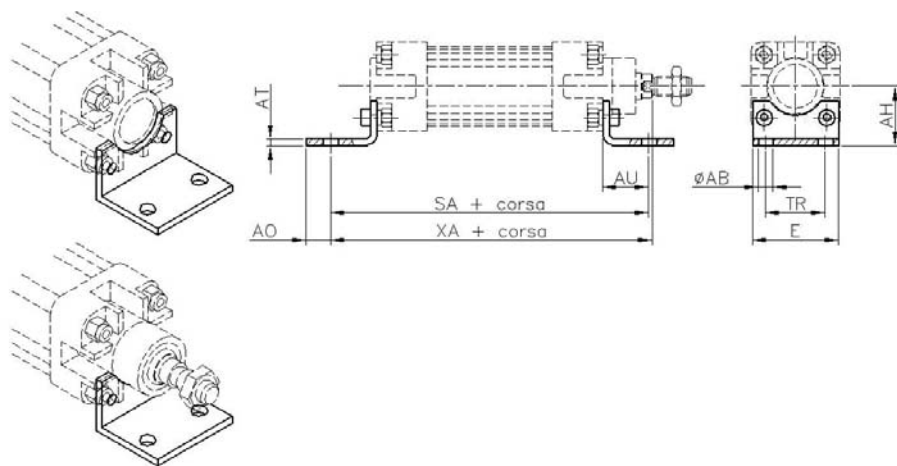

Cil. Ø	Codice	Massa Kg.
32	FM-I13032	0.07
40	FM-I13040	0.09
50	FM-I13050	0.2
63	FM-I13063	0.2
80	FM-I13080	0.4
100	FM-I13100	0.6
125	FM-I13125	1.2
160	FM-I13160	2.4
200	FM-I13200	3.4

Dimensioni flangia ISO MF1-MF2 - Dimension of ISO MF1-MF2 flange

Dimensioni piedino ISO MS1 - Dimension of MS1 angle bracket

Cil. Ø	E (max)	FB H13	MF ±0.2	R JS14	TF JS14	UF (max)	W		ZF		AB H13	AH JS15	AO (max)	AT	AU ±0.2	E (max)	SA		TR JS14	XA	
							Nom.	Toll.	Nom.	Toll.							Nom.	Toll.		Nom.	Toll.
32	45	7	10	32	64	80	16	±1.6	130	±1.25	7	32	11	4	24	45	142	±1.25	32	144	±1.25
40	52	9	10	36	72	90	20	±1.6	145	±1.25	9*	36	15	4	28	52	161	±1.25	36	163	±1.25
50	65	9	12	45	90	110	25	±1.6	155	±1.25	9*	45	15	5	32	65	170	±1.25	45	175	±1.25
63	75	9	12	50	100	120	25	±2	170	±1.6	9*	50	15	5	32	75	185	±1.6	50	190	±1.6
80	95	12	16	63	126	150	30	±2	190	±1.6	12*	63	20	6	41	95	210	±1.6	63	215	±1.6
100	115	14	16	75	150	170	35	±2	205	±1.6	14*	71	25	6	41	115	220	±1.6	75	230	±1.6
125	140	16	20	90	180	205	45	±2.5	245	±2	16*	90	25	8	45	140	250	±2	90	270	±2
160	180	18	20	115	230	260	60	±2.5	280	±2	18*	115	20	10	60	180	300	±2	115	320	±2
200	220	22	25	135	270	300	70	±2.5	300	±2	22*	135	30	10	70	220	320	±2	135	345	±2

* = quota non a norme - non standard dimension

Fissaggi

Mounting brackets

Cerniera in alluminio pressofuso ISO MP2 (femmina), MP4 (maschio) completa di n° 4 viti di fissaggio senza perno
Female/male hinge MP2 in die-cast aluminium with 4 fixing screws

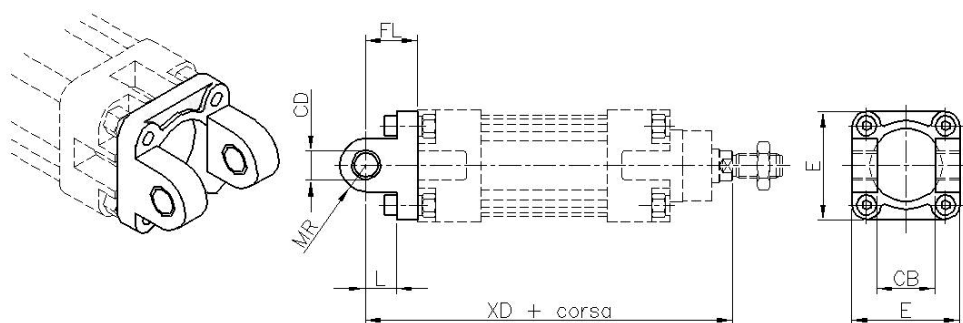

Cil. Ø	Codice	Massa Kg.
32	FM-I10032	0.06
40	FM-I10040	0.08
50	FM-I10050	0.15
63	FM-I10063	0.25
80	FM-I10080	0.36
100	FM-I10100	0.6
125	FM-I10125	1.8
160	FM-I10160	2.4
200	FM-I10200	3.5

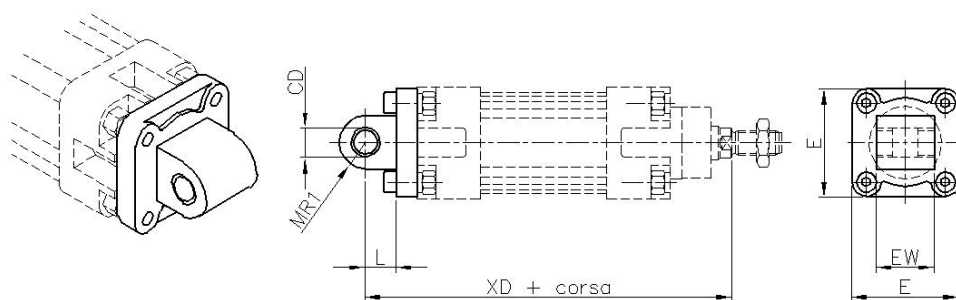

Cil. Ø	Codice	Massa Kg.
32	FM-I11032	0.08
40	FM-I11040	0.1
50	FM-I11050	0.17
63	FM-I11063	0.25
80	FM-I11080	0.42
100	FM-I11100	0.66
125	FM-I11125	1.5
160	FM-I11160	2.3
200	FM-I11200	3.5

Cerniera intermedia ISO MT4 completa con viti di fissaggio (alesaggi 160/200 montata sui tiranti)
Intermediate hinge ISO MT4 with fixing screws (bores 160/200 assembled on tie-rods)

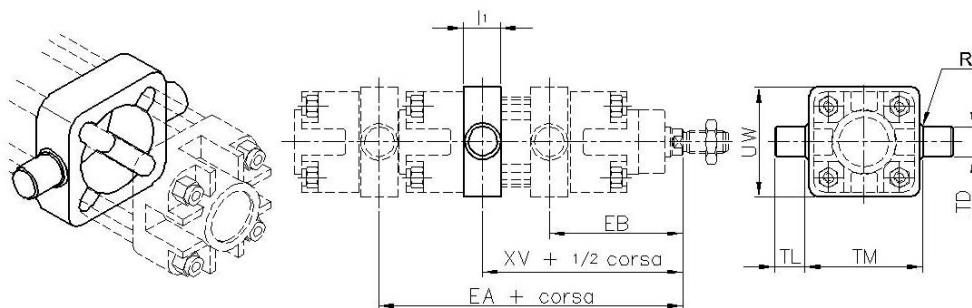

Cil. Ø	Codice	Massa Kg.
32	FM-I14032	0.22
40	FM-I14040	0.34
50	FM-I14050	0.56
63	FM-I14063	0.80
80	FM-I14080	1.3
100	FM-I14100	2
125	FM-I14125	3.2
160	FM-I14160	4.9
200	FM-I14200	7.5

Dimensioni cerniera ISO MP2-MP4 - Dimensions of hinge ISO MP2-MP4

Dimensioni cerniera ISO MT4 - Dimensions of hinge ISO MT4

Cil. Ø	CB	CD	E	EW	FL	L	MR	MR1*	XD	EA	EB	I ₁	R	TD	TL	TM	UW	XV	
																		Nom.	Toll.
32	26	10	45	26	22	12	11	11	142 ±1.25	84	62	18	1	12	12	50	48.5	73	±2
40	28	12	52	28	25	15	13	13	160 ±1.25	94	71	20	1.5	16	16	63	59	82.5	±2
50	32	12	65	32	27	15	13	13	170 ±1.25	102	78	20	1.6	16	16	75	71	90	±2
63	40	16	75	40	32	20	17	23*	190 ±1.6	108	87	26	1.6	20	20	90	84	97.5	±2
80	50	16	95	50	36	20	17	27*	210 ±1.6	124	96	26	1.6	20	20	110	105	110	±2
100	60	20	115	60	41	25	21	29.5*	230 ±1.6	132	108	32	2	25	25	132	129	120	±2
125	70	25	140	70	50	30	26	26	275 ±2	165	125	33	2	25	25	160	154	145	±2.5
160	90	30	180	90	55	35	31	30*	315 ±2	190	150	40	2.5	32	32	200	190	170	±2.5
200	90	30	220	90	60	35	31	30*	335 ±2	205	165	40	2.5	32	32	250	240	185	±2.5

* = quota non a norme - non standard dimension

Fissaggi

Mounting brackets

Ancoraggio per snodo cerniera intermedia Support for intermediate hinge

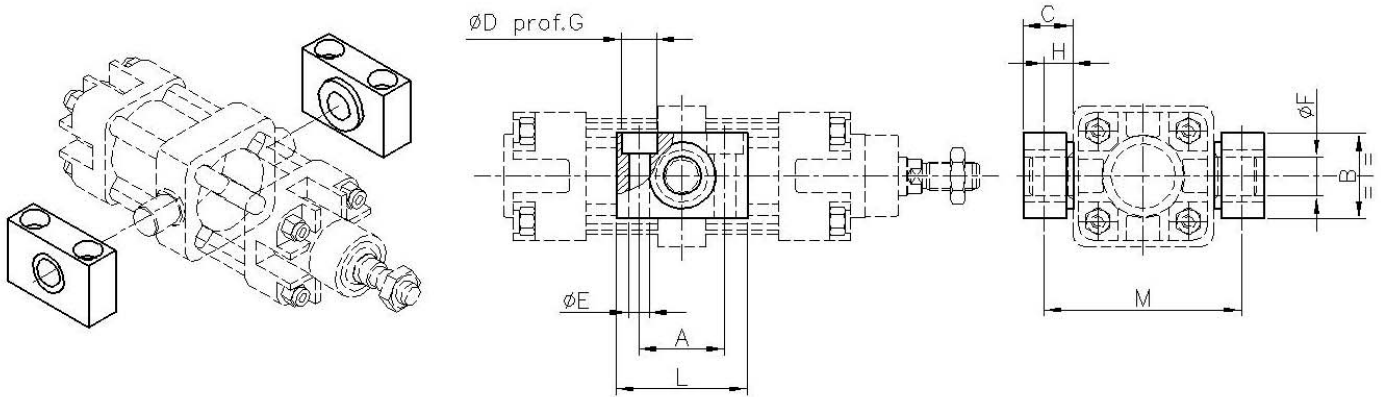

Cil. Ø	GA	GB	GC	GD	GE	GF	GG	GH	GL ±2	GM min.	Codice
32	46	30	18	11	7	12	6.5	10.5	32	72	FM-I25032
40	55	36	21	15	9	16	8.5	12	36	88	FM-I25040
50	55	36	21	15	9	16	8.5	12	36	100	FM-I25040
63	65	40	23	18	11	20	10.5	13	42	117	FM-I25063
80	65	40	23	18	11	20	10.5	13	42	137	FM-I25063
100	75	50	28.5	20	13	25	12.5	16	50	165	FM-I25100
125	75	50	28.5	20	13	25	12.5	16	50	193	FM-I25100

Dado per stelo in acciaio zincato - Piston rod locknut in zinc-plated steel

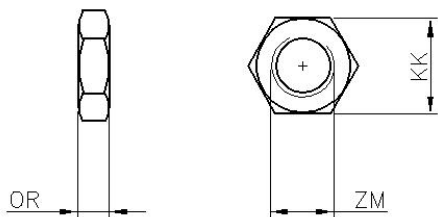

Cil. Ø	ZM	KK	OR	Codice
32	M10 x 1,25	17	6	- KF - 16032
40	M12 x 1,25	19	7	- KF - 16040
50	M16 x 1,5	24	8	- KF - 16050
63	M16 x 1,5	24	8	- KF - 16050
80	M20 x 1,5	30	9	- KF - 16080
100	M20 x 1,5	30	9	- KF - 16080
125	M27 x 1,5	41	12	- KF - 16125
160	M36 x 2	55	14	- KF - 16160
200	M36 x 2	55	14	- KF - 16160

Fissaggi

Mounting brackets

Cerniera maschio snodata in alluminio pressofuso completa di n° 4 viti di fissaggio
Articulated rear hinge in die-cast aluminium with 4 fixing screws

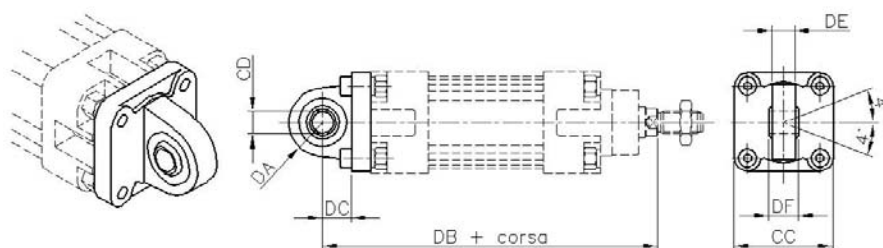

Cil. Ø	Codice	Massa Kg.
32	FM-I24032	0.1
40	FM-I24040	0.2
50	FM-I24050	0.3
63	FM-I24063	0.35
80	FM-I24080	1.6
100	FM-I24100	1.7
125	FM-I24125	2.7

Contro-cerniera a 90° in alluminio pressofuso completa di n° 4 viti di fissaggio
90° counter hinge in die-cast aluminium with 4 fixing screws

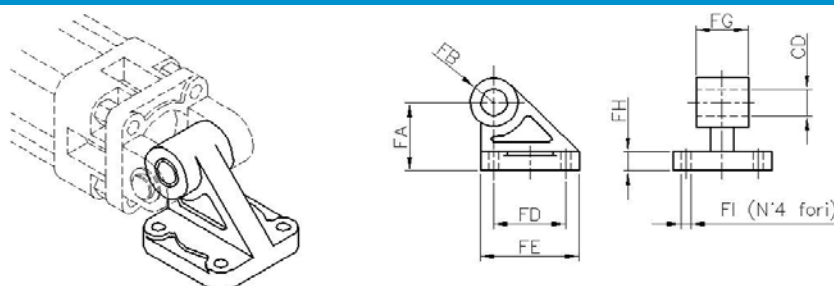

Cil. Ø	Codice	Massa Kg.
32	FM-I19032	0.09
40	FM-I19040	0.12
50	FM-I19050	0.20
63	FM-I19063	0.32
80	FM-I19080	0.58
100	FM-I19100	0.91
125	FM-I19125	0.91

Perno in acciaio zincato completo di n. 2 anelli di arresto
Clevis pin with 2 circlips

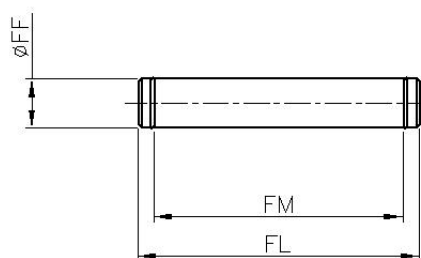

Cil. Ø	Codice	Massa Kg.
32	FM-I18032	0.03
40	FM-I18040	0.05
50	FM-I18050	0.05
63	FM-I18063	0.12
80	FM-I18080	0.15
100	FM-I18100	0.29
125*	FM-I18125	1.53
160*	FM-I18160	1
200*	FM-I18200	1

Dimensioni cerniera maschio snodata <i>Dimensions of articulated rear hinge</i>								Dimensioni contro-cerniera a 90° <i>90° counter hinge dimensions</i>								Dimensioni perno <i>Pin dimensions</i>		
Cil. Ø	CC	CD H9	DA	DB	DC	DE	DF	CD H9	FA	FB	FD	FE	FG	FH	FI	FF f8	FL	FM
32	45	10	16	142	12	10.5	14	10	32	11	32.5	45	25.5	10	7	10	53	46
40	52	12	19	160	15	12	16	12	36	13	38	52	27.5	10	7	12	61.3	53
50	65	12	19	170	15	12	16	12	45	13	46.5	65	31.5	12	9	12	69	61
63	75	16	24	190	20	15	21	16	50	17	56.5	75	39.5	12	9	16	80.5	71
80	95	16	24	210	20	15	21	16	63	17	72	95	49.5	16	11	16	100.5	91
100	115	20	30	230	25	18	25	20	73	21	89	115	59.5	16	11	20	122.5	111
125	140	25	36	275	30	22	31									25	140	131
160																30	181	171
200																30	181	171

Accessori per cilindri

Accessories for cylinders

Cerniera doppia in acciaio zincato per stelo a norma ISO 8140 completa di perno Double hinge in zinc-plated steel with pin for ISO 8140 rod

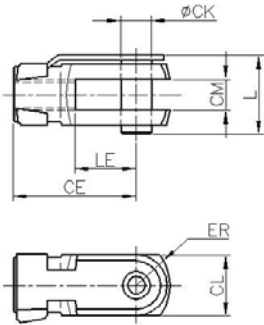

Cil. Ø	CE	CK	CL	CM B12	ER	KK	L	LE	Massa kg	Codice
25-32	40	10	20	10	16	M10 x 1,25	26	20	0,09	FO-I15032
40	48	12	24	12	19	M12 x 1,25	32	24	0,015	FO-I15040
50-63	64	16	32	16	25	M16 x 1,5	39	32	0,34	FO-I15050
80-100	80	20	40	20	32	M20 x 1,5	50	40	0,67	FO-I15080
125	110	30	55	30	45	M27 x 2	65	54	1,79	FO-I15125
160-200	144	35	70	35	57	M36 x 2	81	72	3,87	FO-I15160

Forcella snodata autolubrificante in acciaio zincato Articulated self-lubricating fork in zinc plated steel

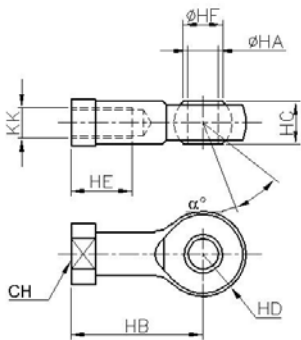

Cil. Ø	α	CH	KK	HA H7	HB	HC	HD 0 -0,12	HE	HF	Massa kg	Codice
25-32	13°	17	M10 x 1,25	10	43	14	14	20	12,9	0,076	FP-I17032
40	13°	19	M12 x 1,25	12	50	16	16	22	15,4	0,11	FP-I17040
50-63	15°	22	M16 x 1,5	16	64	21	21	28	19,3	0,22	FP-I17050
80-100	14°	30	M20 x 1,5	20	77	25	25	33	24,3	0,4	FP-I17080
125	17°	41	M27 x 2	30	110	37	35	51	34,8	1,12	FP-I17125

Forcella con perno snodato in asse Fork with axially mounted articulated pin

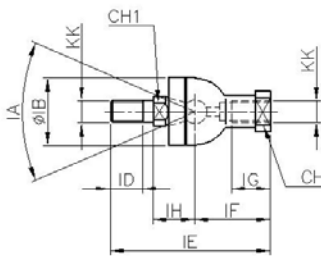

Cil. Ø	CH	CH1	IA	KK	IH ±0,3	IB	ID	IE	IF	IG	Massa kg	Codice
25-32	17	11	30°	M10 x 1,25	19,5	32	15	74,5	35	18	0,12	FP-I22032
40	19	17	30°	M12 x 1,25	22	36	17	84	40	20	0,185	FP-I22040
50-63	22	19	22°	M16 x 1,5	27,5	47	23	112	50	27	0,36	FP-I22050
80-100	30	24	15°	M20 x 1,5	31,5	58	25	133	63	38	0,57	FP-I22080

Forcella con perno snodato ad angolo Fork with angle mounted articulated pin

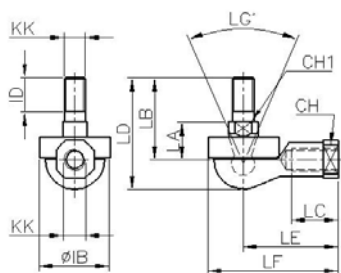

Cil. Ø	CH	CH1	LG	KK	IB	ID	LA ±0,3	LB	LC	LD	LE	LF	Massa kg	Codice
25-32	17	11	50°	M10 x 1,25	32	15	17	37	21	50,5	43	57	0,11	FP-I23032
40	19	17	50°	M12 x 1,25	36	17	19	42	27	57,5	50	66	0,165	FP-I23040
50-63	22	19	40°	M16 x 1,5	47	23	23,5	60	33	79,5	64	84	0,33	FP-I23050
80-100	30	24	32°	M20 x 1,5	58	25	27	68	40	90	77	90	0,54	FP-I23080

Sensori di prossimità per cilindri magnetici

Proximity sensors for magnetic cylinders

Sensori carica dall'alto - Top assembly sensors

I sensori magnetici sono rilevatori elettrici che interagiscono con un campo magnetico; montati sulla camicia di un cilindro, rilevano la posizione del campo magnetico generato da un disco in plastoferrite montato nel pistone. Un led luminoso segnala il cambiamento di stato del sensore e il conseguente segnale di uscita viene quindi utilizzato come input per ulteriori funzioni elettriche. Questi sensori sono applicabili a molte tipologie di cilindri mediante l'utilizzo degli appropriati sistemi di fissaggio che possiamo fornire.

Magnetic sensors are electric detectors that act with a magnetic field; fitted on the extruded barrel, they detect the magnetic field produced by a plastoferrite disk mounted inside the piston. A bright led points out the sensor status change and the consequent outlet signal is therefore used as input for further electric functions. These sensors can be applied in many kinds of cylinders through the use of proper fixing systems, which can be supplied by us.

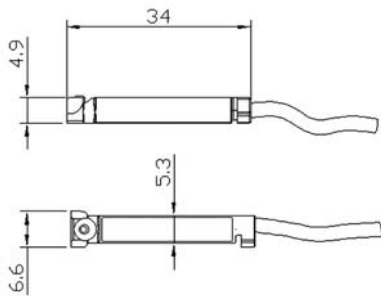

Dati tecnici - Technical data

Descrizione		Valore	
N. di conduttori		2	3
Sistemi di fissaggio		molla snap + vite	
Materiale vite di fissaggio		Cu Zn nickelata	
Materiale custodia		PA	
Materiale isolante		resina epossidica	
Grado di protezione	IEC 60 529	IP 67	
Portata nominale	Reed	200mA-6W	500mA-6W
	Magneto res.		200mA-4W
Tensione di lavoro	Reed	5-130V AC/DC	5-50V AC/DC
	Magneto res.		3-28V DC
Vita elettrica	Reed	10 ⁷	
	Magneto res.	10 ⁹	

Dati tecnici - Technical data

Schema circuito	Connettore M8	Tensione	Dati elettrici	Portata	Lunghezza
		5-130V AC-DC	200mA-6W	2 m	
		5-130V AC-DC	200mA-6W	5 m	
		5-130V AC-DC	200mA-6W	10 m	
		5-30V AC-DC	500mA-6W	2 m	
		5-30V AC-DC	500mA-6W	5 m	
		5-30V AC-DC	500mA-6W	10 m	
		3-28V DC	200mA 4W	2 m	
		3-28V DC	200mA 4W	5 m	
		3-28V DC	200mA 4W	10 m	
		3-28V DC	200mA 4W	0,3 m	

Montaggio - Assembly

- Inserire dall'alto il sensore come indicato in figura
- Ruotare di 90° il corpo del sensore
- Allargare il sensore nella cava tenendo in vista il taglio del grano
- Individuata la posizione di lettura, avvitare il grano

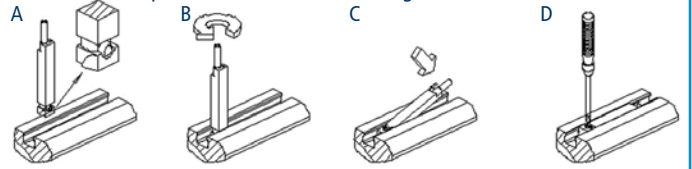

Staffe per cilindri ISO - Bracket for ISO cylinders

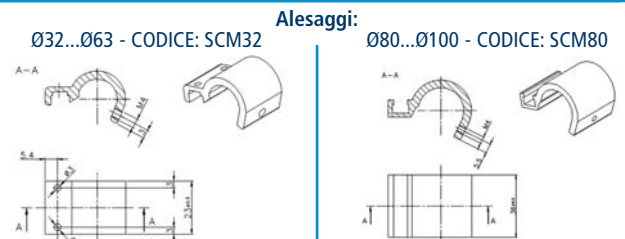

Fascetta per microcilindri - Locking bands for microcylinders



Alesaggio	Codice
8	SF08
12	SF12
16	SF16
20	SF20
25	SF25

Adattatore per il montaggio su cilindri Adaptors for cylinders

